

# **Retrofitting Existing Buildings for Demand Response & Energy Efficiency**

*[www.CypressEnviroSystems.com](http://www.CypressEnviroSystems.com)*

# Who is Cypress Envirosystems?

- Mission:
  - Save energy, enable demand response, improve productivity for older facilities.
  - Use technologies which minimize disruption, install in minutes, no retraining of staff.
  - Target payback of less than 18 months.
- Subsidiary of Cypress Semiconductor (\$1B company), sister company of SunPower
- CEO: Harry Sim, ex-Honeywell, 15yrs.



Cutting Edge  
Silicon Valley  
Technology

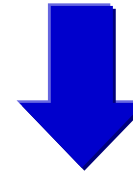

*Applied to Legacy Facilities*



# Cypress Envirosystems: Problems We Solve...



*Pneumatic  
Thermostats*



*Dial Gauges*



*Steam Traps*

Need to save energy & improve uptime, but hindered by outdated facility?



*Standalone Transducers,  
LED/LCD Displays*



*-80C Freezers*



*Legacy Fluorescent  
Lighting*



*Uninterruptible  
Power Supplies*

**Manual Instrumentation, Not Programmable, No Diagnostics...  
Equals: Wasted Energy, Higher Downtime, More Labor Required**

# What is our Solution?



**WIRELESS PNEUMATIC THERMOSTAT**  
*"Go from Pneumatic to DDC in minutes"*



**WIRELESS GAUGE READER**  
*"Remotely Read Gauges in minutes"*



**WIRELESS STEAM TRAP MONITOR**  
*"Avoid Expensive Steam Leaks"*



**BLUE BOX HUB/RECEIVER**



**WIRELESS TRANSDUCER READER**  
*"Remotely Read Transducers – No Wires"*

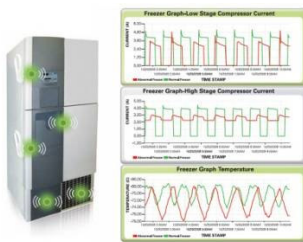

**WIRELESS FREEZER MONITOR**  
*"Predicts and Avoids Costly Freezer Failure"*



**WIRELESS LIGHT CONTROLLER**  
*"Reduce Electricity Use"*



**WIRELESS BATTERY MONITOR**  
*"Automates UPS Health Check"*

**Non-invasive, easy retrofit, energy and labor savings, payback under one year**

# Energy Use in Commercial Buildings

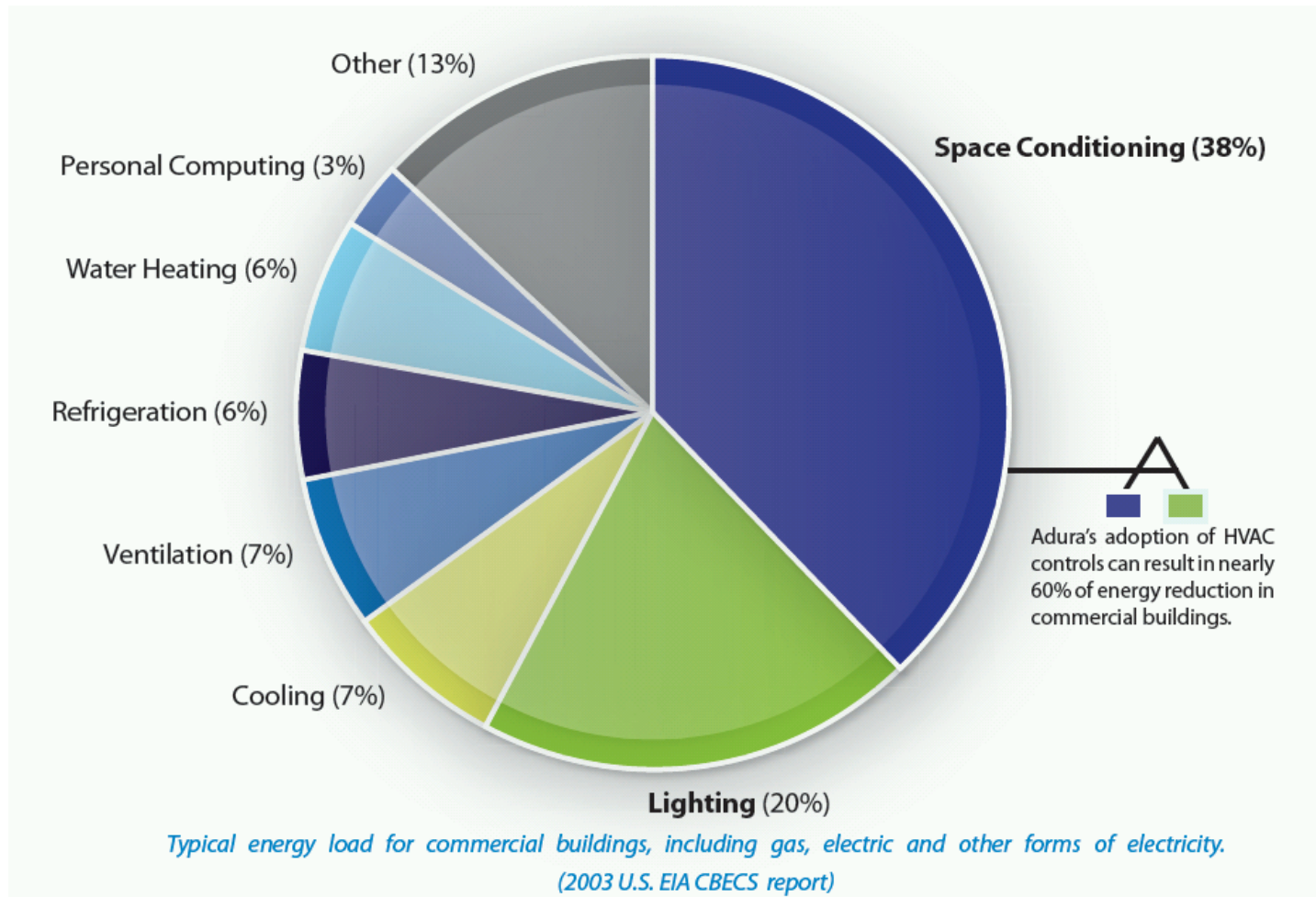

**HVAC and Lighting... More than 60% of Energy Use**

# Regulation Drivers: California Example

- **Default Critical Peak Pricing**

- Starting May 1<sup>st</sup>, 2010, virtually all commercial office building customers will move to a default electricity pricing rate called Critical Peak Pricing  
[www.pge.com/mybusiness/energysavingsrebates/demandresponse/cpp/](http://www.pge.com/mybusiness/energysavingsrebates/demandresponse/cpp/)
- This rate structure provides for discounted rates when no CPP events are called. However, on CPP event days, higher “critical peak” energy charges will be assessed for usage between noon and 6pm.
- Customers are notified by PG&E by 3pm the day prior to the critical event.
- Customers with Auto-Demand Response enabled buildings (e.g. communicating thermostats, lighting etc.) can automatically reduce usage using these high rate periods to avoid high charges.

- **Assembly Bill 1103 – Building Energy Efficiency Disclosure**

- Starting January 1, 2010, all commercial building lease transactions must disclose the energy efficiency history and Energy Star rating of the facility. More efficient buildings will be able to attract premium tenants, and potentially command a rental premium.

Source: California Public Utilities Commission Decision, July 31<sup>st</sup>, 2008 (see page 21 and Attachment B)  
[http://docs.cpuc.ca.gov/word\\_pdf/FINAL\\_DECISION/85984.pdf](http://docs.cpuc.ca.gov/word_pdf/FINAL_DECISION/85984.pdf)

***Peak Load 50% over Base Load – Mostly Commercial Buildings.  
Peak Load Costs \$100-150/kW To Keep on Standby.***



# ***Retrofit of Pneumatic HVAC Controls***

# 70% of Commercial Buildings Still Pneumatic

- **Waste energy, more maintenance, unhappy tenants...**
  - No Night Setback, No Zone Control, No Optimal Start/Stop, No Occupancy Override, No Demand Response...
- **High Cost to Retrofit**
  - Market rate of \$2500 - \$3000 per zone for traditional DDC retrofit
- **Disruptive to Tenants**
  - Open Walls, Ceiling, Exposure to Asbestos



***Retrofitting Existing Buildings is a PAIN IN THE NECK!!***



# Wireless Pneumatic Thermostat (WPT)

*EXISTING LEGACY STAT*



- Manual Setpoint Control
- No Remote Readings
- No Diagnostics
- Manual Calibration Required
- Cannot support Demand Response strategies

**DDC in 20 Minutes!**

*CYPRESS ENVIROSYSTEMS  
WIRELESS PNEUMATIC THERMOSTAT*



- Remote Wireless Setpoint Control
- Remote Monitoring of Temperature & Pressure
- Pager/Cell Notification of Excursions
- Automatic Self-calibration
- Programmable Temperature Setbacks
- Occupancy Override
- Enables Demand Response strategies
- BACnet Interface to BMS
- Compatible With Existing Johnson, Honeywell, Siemens, Robertshaw
- Minimum 2yr battery life

**Get the benefits of Direct Digital Control (DDC) in less than 20 minutes, 80% Lower Cost**

# Enabling Smart Grid – Auto Demand Response

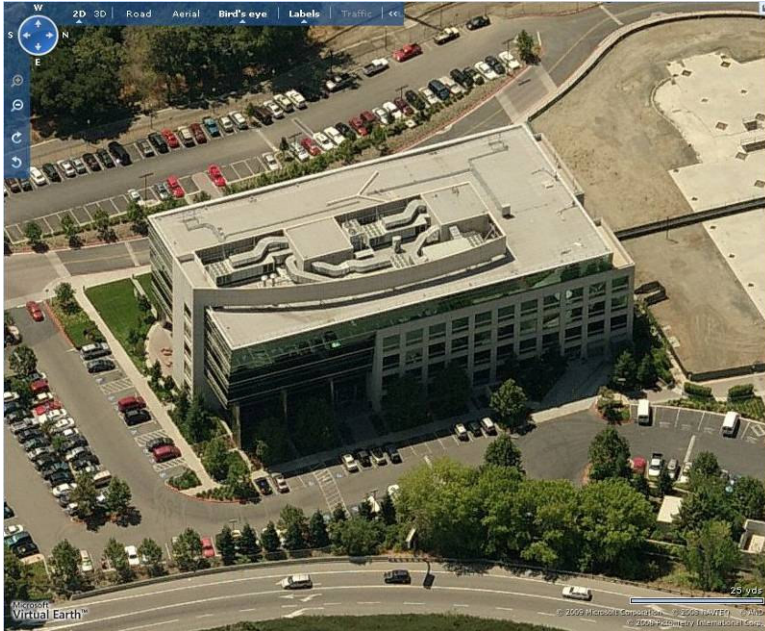

- County of Santa Clara, Social Services Administration
- 2 Buildings, each 5 story, built 2000
- Total 300,000 sq-ft
- 350 Pneumatic Thermostats, non-communicating
- Estimated Demand Response load shed: 200kW
- Would like to participate in PG&E Auto-DR program, but challenging with pneumatic thermostats

# 15 Minute Replacement of Thermostat

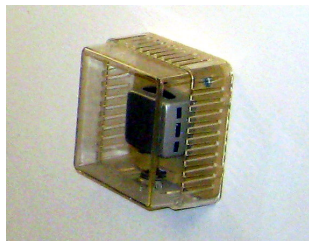

# 80% Lower Cost, 5% of the Time vs. Conventional DDC

## Santa Clara County Government Project



	<b>Cypress Envirosystems Wireless Pneumatic Thermostats Retrofit</b>	<b>Conventional Direct Digital Control Retrofit</b>
Installed Price	350 x \$500 = \$175,000	350 x \$2,500 = \$875,000
Time Required	8 days	6 months
Disruption to Operations	Minimal	Significant
Potential Exposure to Toxic Substances in Walls	None	Unknown
Paid for by PG&E Auto DR Incentive	100% covered	31% covered

**“Installation took only eight days and was one of the easiest, fast and most cost effective energy efficiency improvements we have ever made in our buildings”**

**- Jeff Draper, Manager of Building Operations**

# Quantified Savings for Santa Clara County

- 300,000 sq-ft facility, \$175,000 cost to retrofit (before utility incentives)
- Energy Savings: \$42,000 per year
  - 350,000 kWh per year base load reduction, at \$0.12 per kWh
  - Derived from enforcing Temperature Setpoint Policy and Retrocommissioning
- Demand Response Savings: \$7,500 per year
  - 10,700 kWh curtailed at peak rates \$0.70 per kWh
  - Based on 12 events per year, 4 hours each, 0.6kW shed per thermostat
- Maintenance Cost Savings: \$156,000 per year
  - Continuous commissioning data helped prioritize maintenance and reduced troubleshooting time
- Estimated Payback Period for Santa Clara County Project: 16 months *BEFORE UTILITY INCENTIVES*
  - Some savings kick in partially in first year, fully in subsequent years.

# Wireless Pneumatic Thermostat Savings

**Estimated Savings Potential**  
 \$635/year (per 1000 sq-ft)  
 Upfront Retrofit Cost: \$600 (per 1000 sq-ft)  
 Payback Period: 11 months

*Note: All calculations based on 300,000 sq-ft retrofit project, \$0.10 per kWh electricity rate, and \$80 per hour maintenance labor rate.*

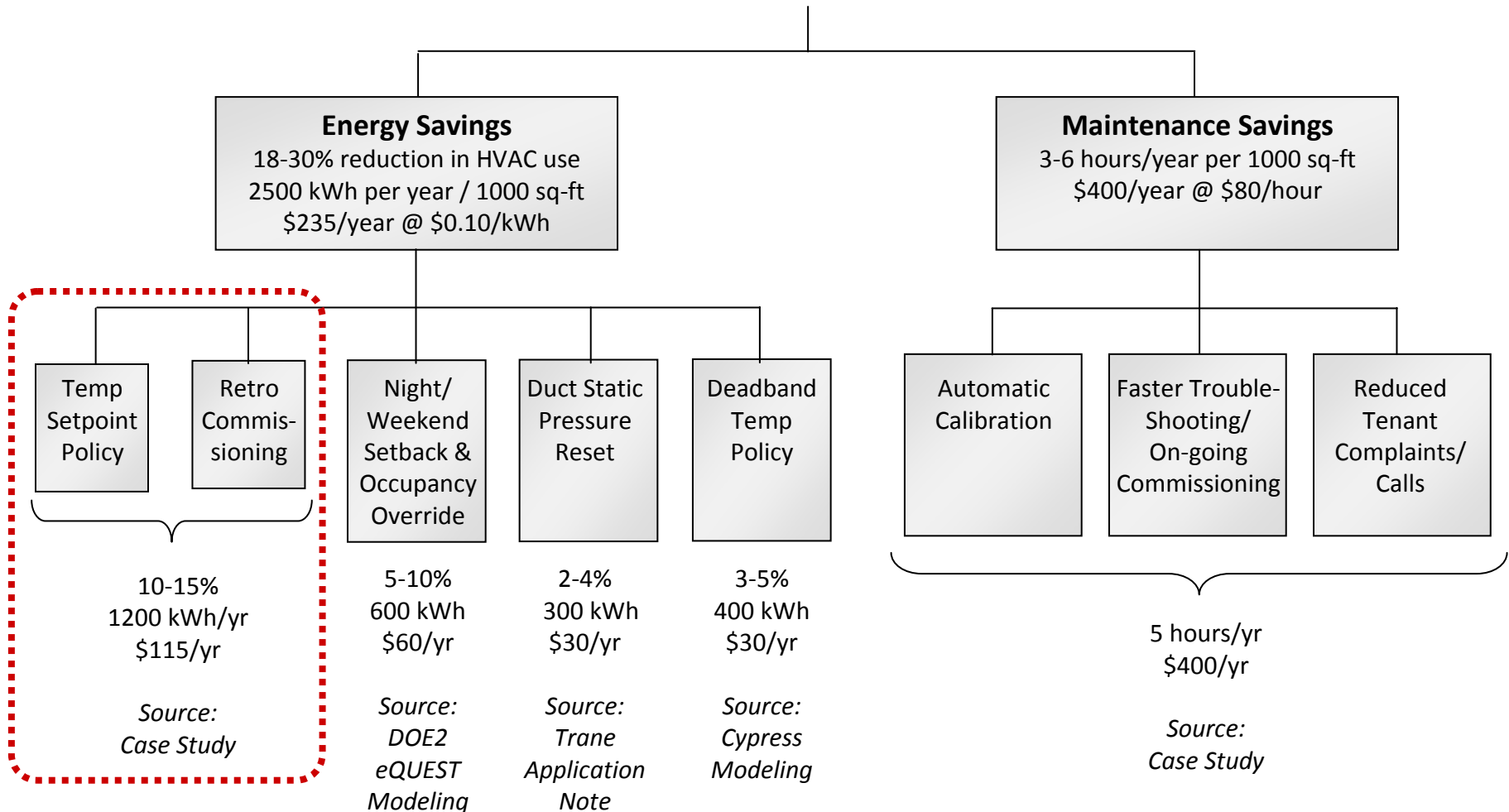

# Temp Setpoint Policy / Retrocommissioning Savings

## Enforcing Temperature Setpoint Policy

- Conventional Pneumatic Thermostats drift out of calibration, and are often set on max or min by occupants.
- Result: zones often over-cool or over-heat, and even fight among each other, wasting energy.
- WPT Solution: Enforce thermostat setpoint remotely. Monitor constantly and set alarms if over/below limits.

## Retrocommissioning

- Conventional Pneumatic Thermostats, do not provide any data for diagnostics
- Result: malfunctioning zones are not detected or corrected, wasting energy.
- WPT Solution: Monitoring data enable discrepancies to be quickly identified. Take Low-cost or no-cost retrocommissioning steps to correct.

# Zone Behavior – Proper Response (example)

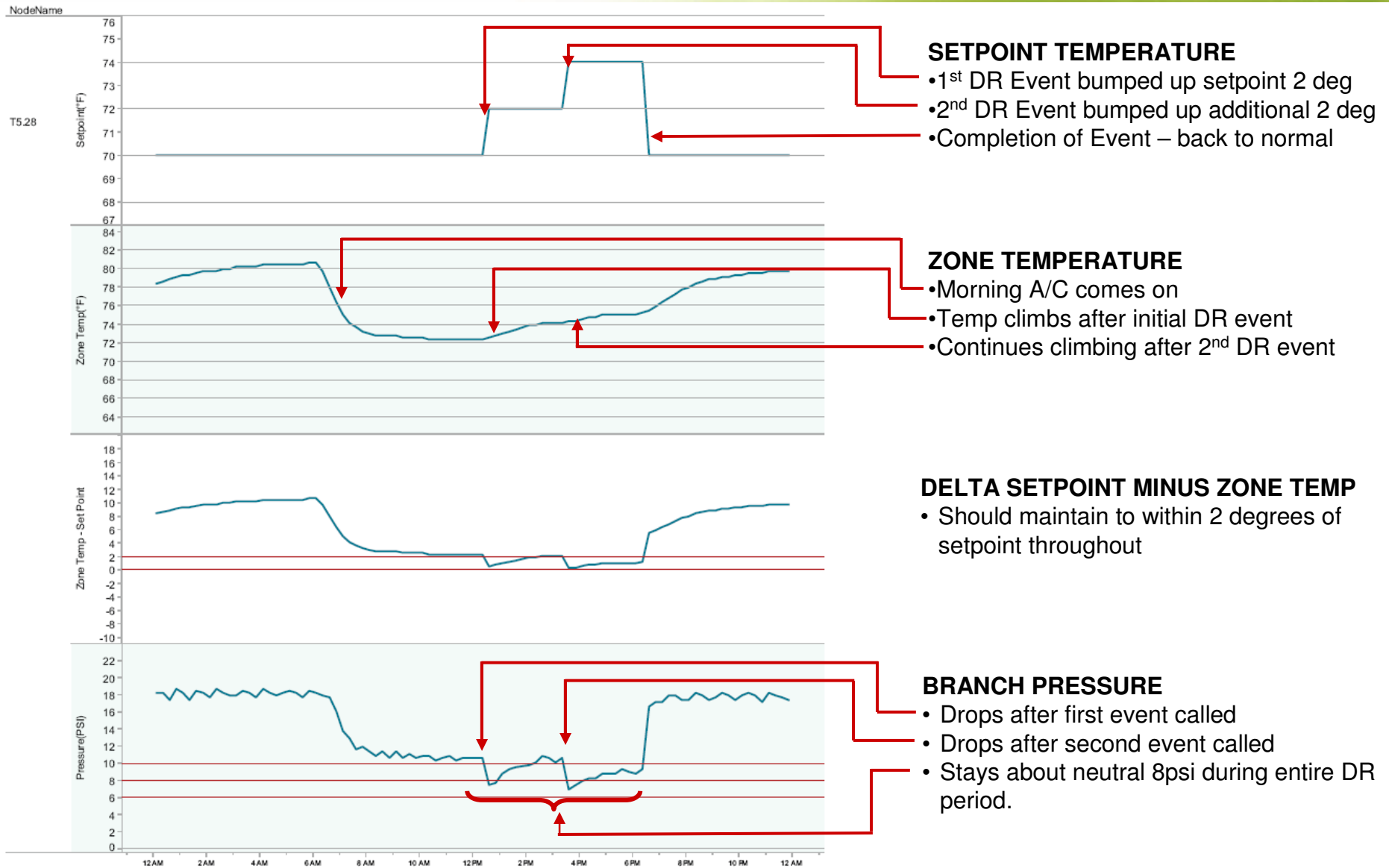



# Zone Behavior – Insufficient Cooling (example)

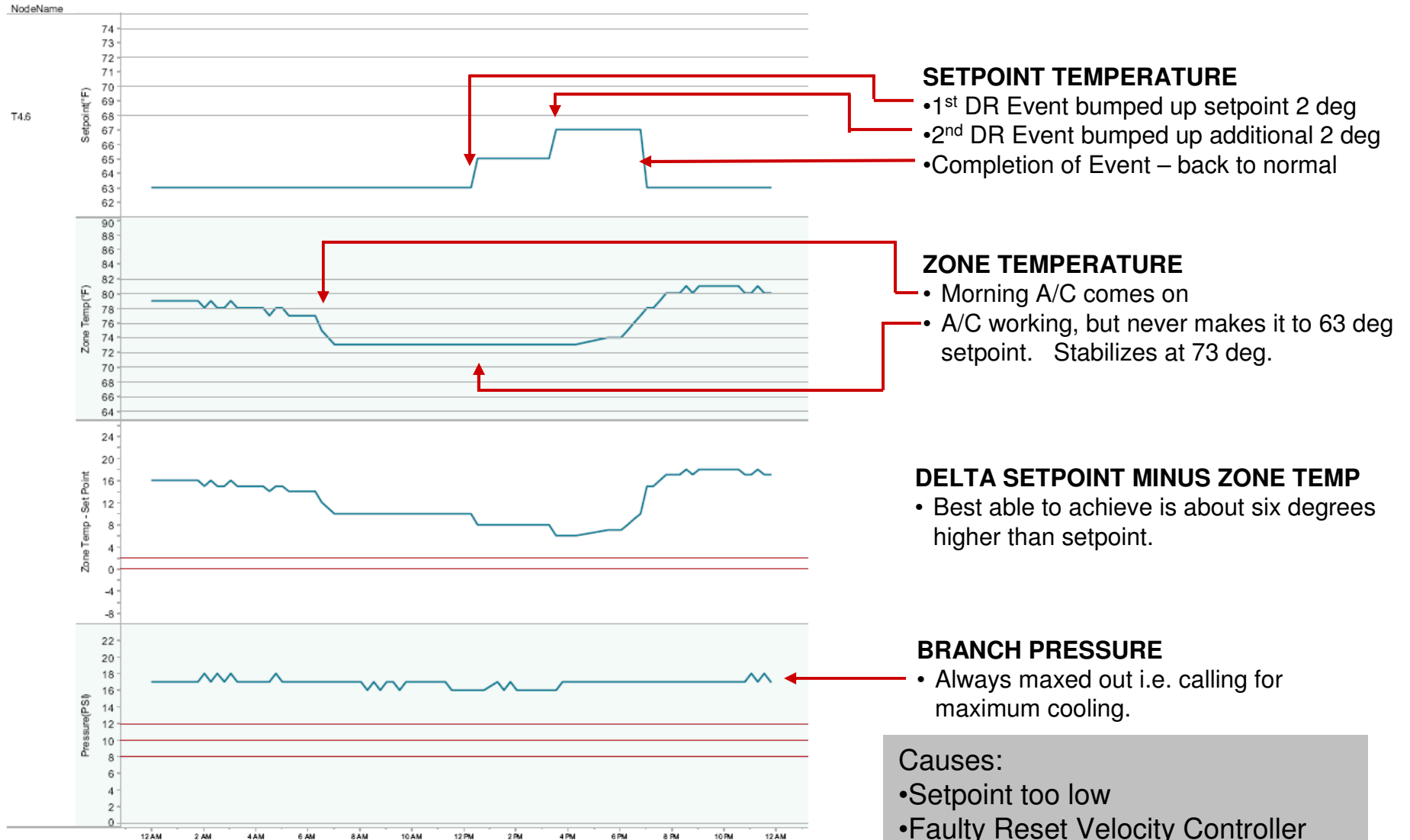

### SETPOINT TEMPERATURE

- 1<sup>st</sup> DR Event bumped up setpoint 2 deg
- 2<sup>nd</sup> DR Event bumped up additional 2 deg
- Completion of Event – back to normal

### ZONE TEMPERATURE

- Morning A/C comes on
- A/C working, but never makes it to 63 deg setpoint. Stabilizes at 73 deg.

### DELTA SETPOINT MINUS ZONE TEMP

- Best able to achieve is about six degrees higher than setpoint.

### BRANCH PRESSURE

- Always maxed out i.e. calling for maximum cooling.

Causes:

- Setpoint too low
- Faulty Reset Velocity Controller
- Mechanical Equipment Fault
- Undersized cooling capacity design

# Zone Behavior – Too Much Cooling (example)

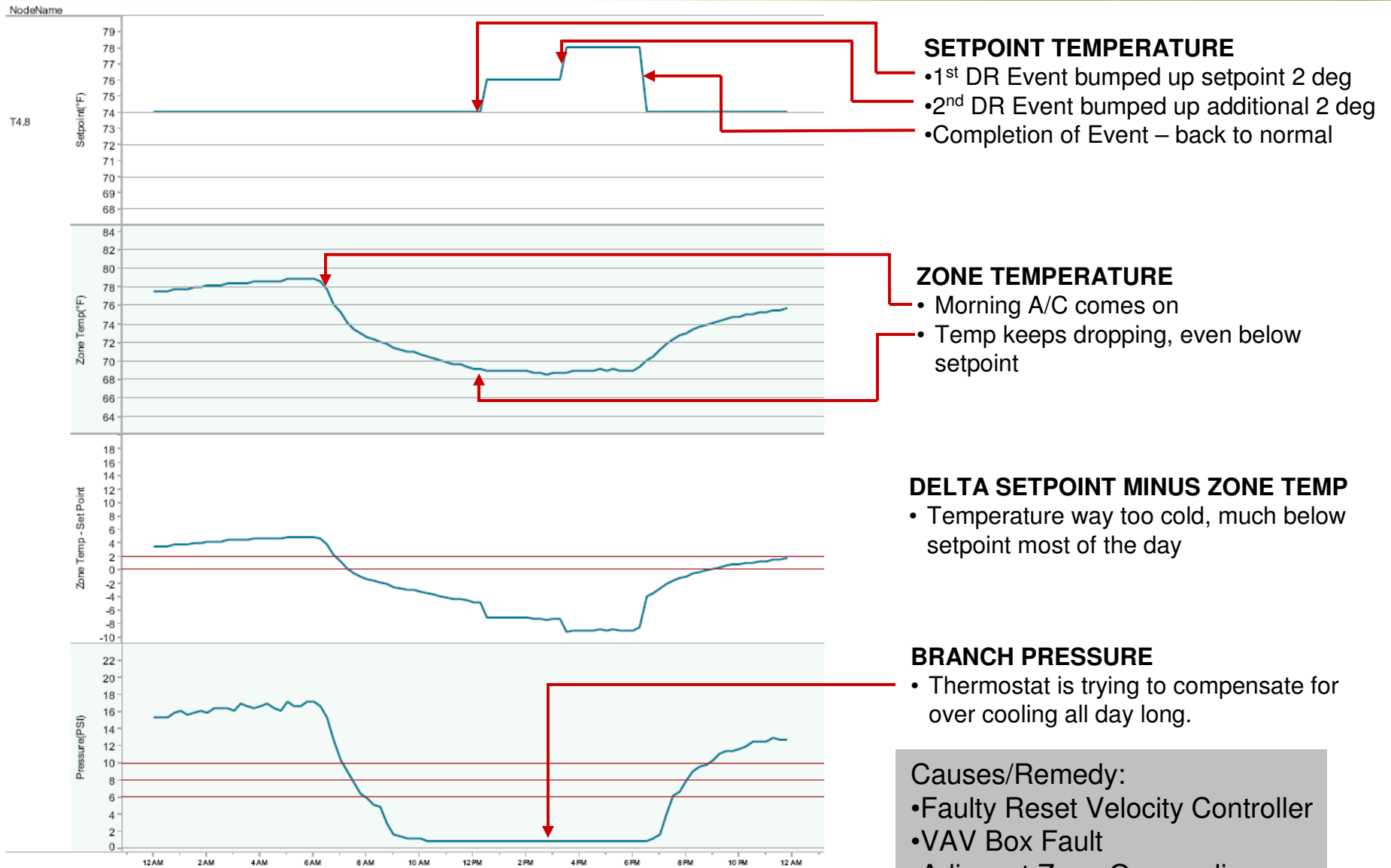

## SETPOINT TEMPERATURE

- 1<sup>st</sup> DR Event bumped up setpoint 2 deg
- 2<sup>nd</sup> DR Event bumped up additional 2 deg
- Completion of Event – back to normal

## ZONE TEMPERATURE

- Morning A/C comes on
- Temp keeps dropping, even below setpoint

## DELTA SETPOINT MINUS ZONE TEMP

- Temperature way too cold, much below setpoint most of the day

## BRANCH PRESSURE

- Thermostat is trying to compensate for over cooling all day long.

## Causes/Remedy:

- Faulty Reset Velocity Controller
- VAV Box Fault
- Adjacent Zone Overcooling

# Actual Case Study Results: 15% Savings

- Santa Clara County Government Buildings – 300,000 sq-ft retrofit completed in March 2009.
- Actual Post-retrofit energy use compared with same period in prior year, adjusted for deg-days.
- Reduction in HVAC energy use of 15% due to temperature setpoint policy and retrocommissioning.

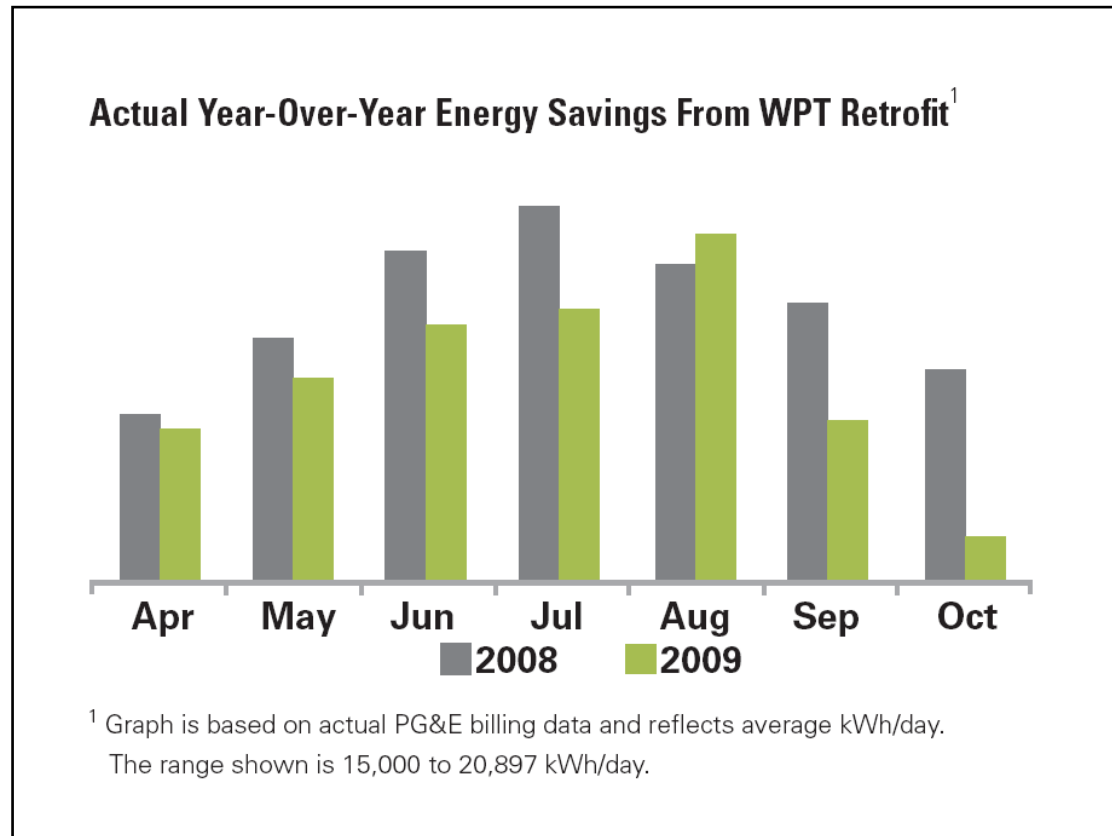

Full case study available at: [http://www.cypressenvirosystems.com/files/pdf/CountyofSantaClara\\_EnergySavings\\_Final.pdf](http://www.cypressenvirosystems.com/files/pdf/CountyofSantaClara_EnergySavings_Final.pdf)

**Documented 15% Reduction on HVAC Energy Use vs. Prior Year Due to Retrocommissioning and Temperature Setpoint Policy Enforcement**

# Wireless Pneumatic Thermostat Savings

**Estimated Savings Potential**  
 \$635/year (per 1000 sq-ft)  
 Upfront Retrofit Cost: \$600 (per 1000 sq-ft)  
 Payback Period: 11 months

*Note: All calculations based on 300,000 sq-ft retrofit project, \$0.10 per kWh electricity rate, and \$80 per hour maintenance labor rate.*

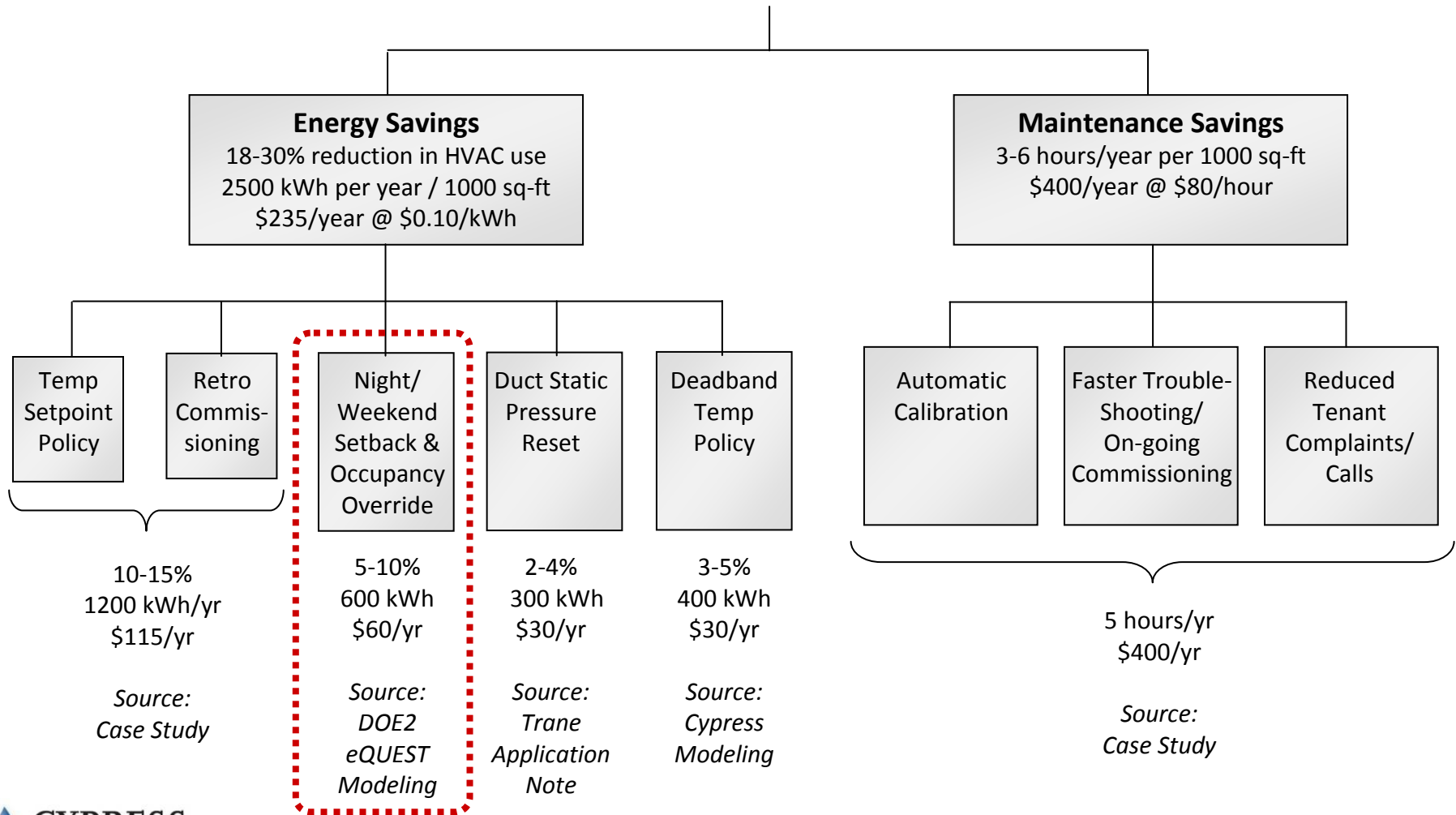

# Temp Setpoint Policy / Retrocommissioning Savings

## Weekend/Night Setback

- Many buildings have mixed use occupants with different use schedules e.g. 24x7 data centers, vs. 9-5 offices
- Pneumatic Thermostats do not allow programmable zone controls.
- Result: Zones are cooled or heated even when they are not occupied.
- WPT Solution: Temperature Setbacks can be programmed for different zones to reduce unnecessary energy use.

## Occupancy Override

- Occupants may override programmed weekend or night setback if they are working late or on weekends.
- Front panel buttons on the WPT allow occupants to select override for temporary durations.
- Log of override zones are available to the building manager for optional billing allocation of costs.

# Actual Case Study Results: 10% Savings

- Los Angeles Area Chamber of Commerce Building – 80,000 sq-ft retrofit completed in Sept 2009.
- Calculated energy savings for night/weekend setback using DOE2 eQUEST tool from US Dept. of Energy.
- Predicted reduction in HVAC energy use of 10%.

Project/Run: LA Chamber of Com - Baseline Design

Run Date/Time: 05/13/09 @ 13:54

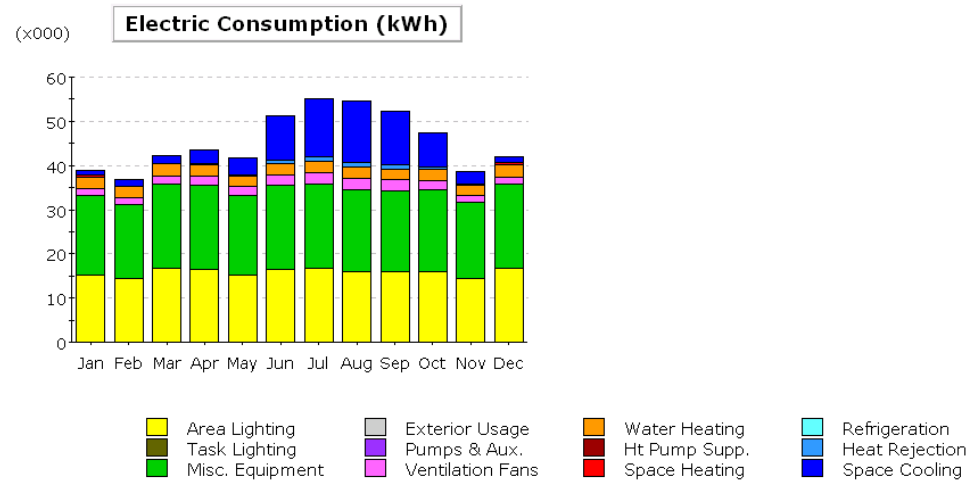

Electric Consumption (kWh x000)

	Jan	Feb	Mar	Apr	May	Jun	Jul	Aug	Sep	Oct	Nov	Dec	Total
Space Cool	0.85	1.55	1.78	2.98	3.87	10.08	13.27	14.05	12.24	7.87	3.00	1.14	72.67
Heat Reject.	0.03	0.07	0.08	0.16	0.21	0.68	1.00	1.07	0.92	0.55	0.15	0.04	4.96
Refrigeration	-	-	-	-	-	-	-	-	-	-	-	-	-
Space Heat	0.61	0.06	0.04	0.01	0.00	-	-	-	-	-	0.01	0.57	1.30
HP Supp.	-	-	-	-	-	-	-	-	-	-	-	-	-
Hot Water	2.51	2.40	2.77	2.75	2.46	2.61	2.56	2.42	2.41	2.45	2.28	2.68	30.31
Vent. Fans	1.49	1.53	1.83	1.99	1.88	2.39	2.58	2.60	2.46	2.10	1.54	1.65	24.06
Pumps & Aux.	0.04	0.04	0.05	0.05	0.04	0.05	0.05	0.04	0.04	0.04	0.04	0.05	0.52
Ext. Usage	-	-	-	-	-	-	-	-	-	-	-	-	-
Misc. Equip.	18.06	16.80	19.11	18.86	18.06	18.86	19.11	18.59	18.34	18.59	17.30	19.11	220.79
Task Lights	-	-	-	-	-	-	-	-	-	-	-	-	-
Area Lights	15.17	14.38	16.62	16.60	15.17	16.60	16.62	15.90	15.87	15.90	14.43	16.62	189.89
<b>Total</b>	<b>38.76</b>	<b>36.83</b>	<b>42.28</b>	<b>43.40</b>	<b>41.71</b>	<b>51.28</b>	<b>55.18</b>	<b>54.68</b>	<b>52.29</b>	<b>47.50</b>	<b>38.74</b>	<b>41.85</b>	<b>544.49</b>

**Calculated 10% Reduction on HVAC Energy Using eQUEST Modeling Software from the US Department of Energy**

# Wireless Pneumatic Thermostat Savings

**Estimated Savings Potential**  
 \$635/year (per 1000 sq-ft)  
 Upfront Retrofit Cost: \$600 (per 1000 sq-ft)  
 Payback Period: 11 months

*Note: All calculations based on 300,000 sq-ft retrofit project, \$0.10 per kWh electricity rate, and \$80 per hour maintenance labor rate.*

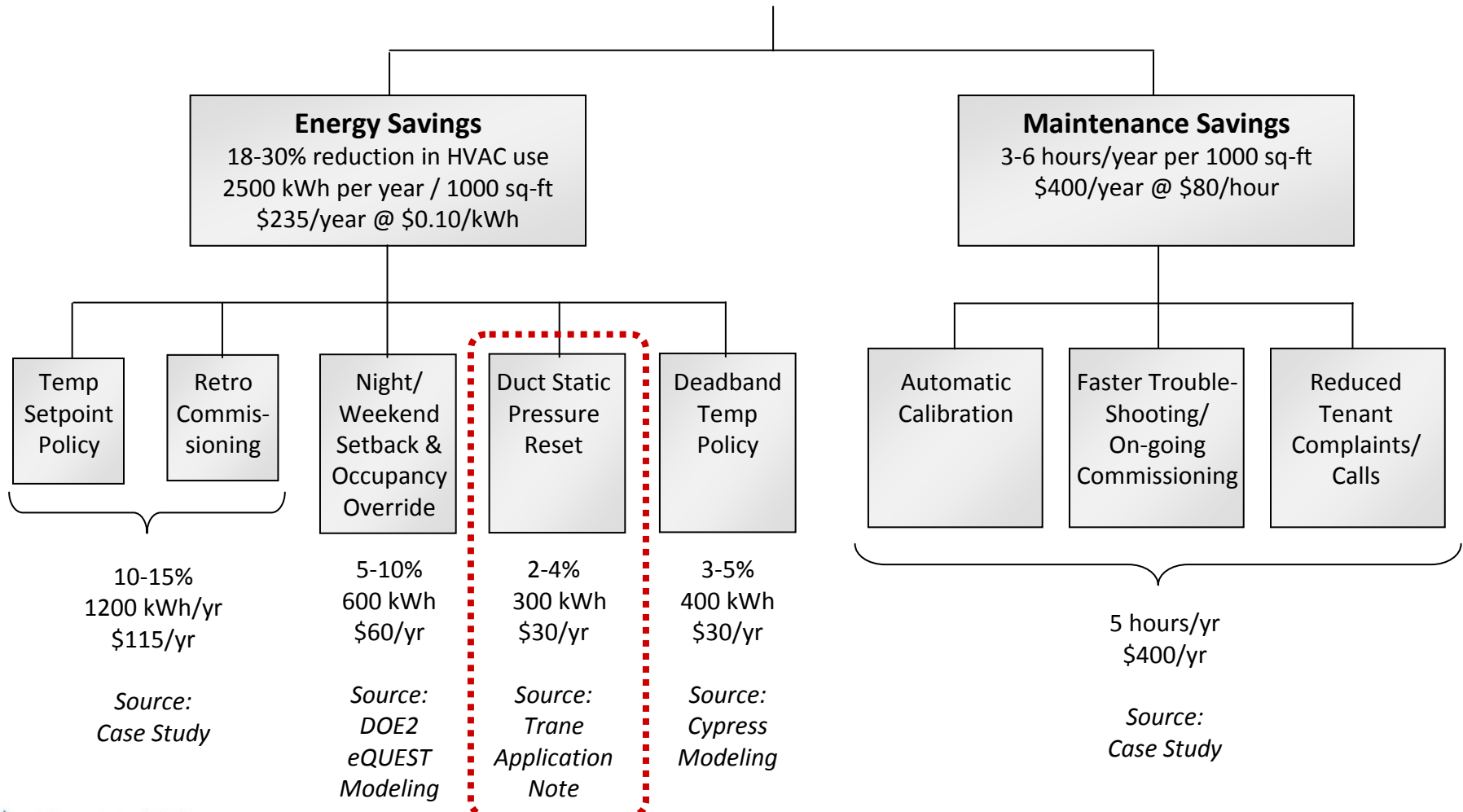

## Duct Static Pressure Reset Savings

- Reduce Ventilation Fan Speed / Duct Static Pressure when heating/cooling not required. Keep at minimum for Indoor Air Quality
- When heating/cooling required, increase fan speed for proper temperature control
- Save energy by reducing fan load when not needed.
- WPT Solution: Built-in branch pressure sensor directly indicates heating or cooling load, and enables existing Building Management Systems to control fan speed appropriately.

**Trane Models for DDC Systems Show 2-4% Energy Savings from Duct Static Pressure Reset. WPT Achieves Same Application with Pneumatic System.**



# Wireless Pneumatic Thermostat Savings

**Estimated Savings Potential**  
 \$635/year (per 1000 sq-ft)  
 Upfront Retrofit Cost: \$600 (per 1000 sq-ft)  
 Payback Period: 11 months

*Note: All calculations based on 300,000 sq-ft retrofit project, \$0.10 per kWh electricity rate, and \$80 per hour maintenance labor rate.*

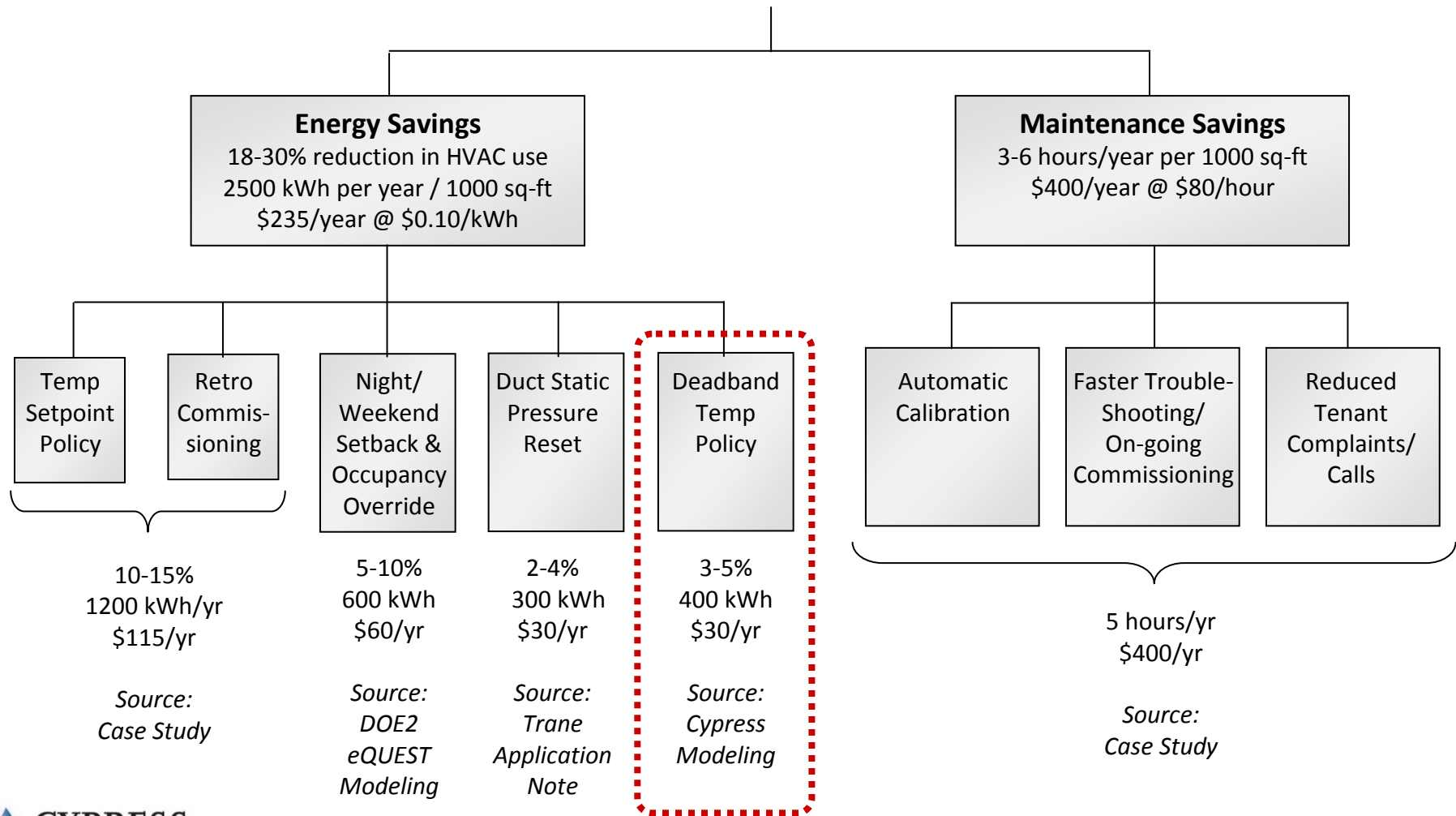

# Deadband Temperature Setpoint Policy

## What is it?

- When zone temperature is within certain limits e.g. between 68F and 78F, *ALL HEATING AND COOLING IS DISABLED* for that zone.
- When ambient temperature is outside these limits, heating and cooling is *ENABLED* to maintain basic comfort.

## Why?

- Up to 60% energy savings potential, for occupants who can tolerate some range of temperature swing.
- Many universities and public institutions have mandated this type of temperature setpoint policy...the Deadband WPT enables and automatically enforces the policy.
- Benefits are INCREMENTAL to Night Setback, Occupancy Override, Demand Response and other energy management strategies available

# Comparison: Standard Pneumatic vs. Deadband Function

### Standard Pneumatic Thermostat Behavior (Typical, Direct Acting)

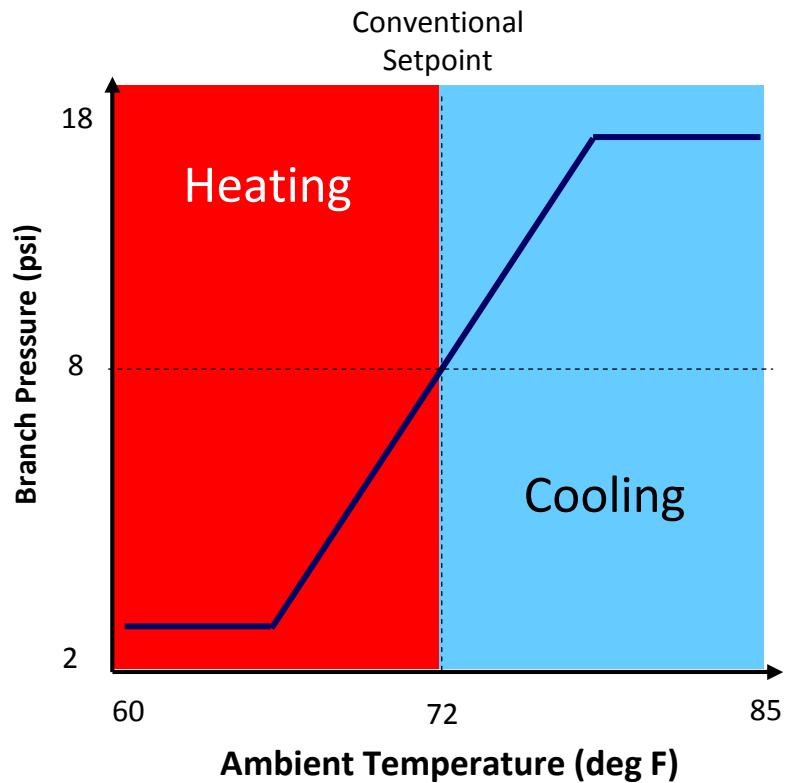

### Deadband Pneumatic Thermostat Behavior (Typical, Direct Acting)

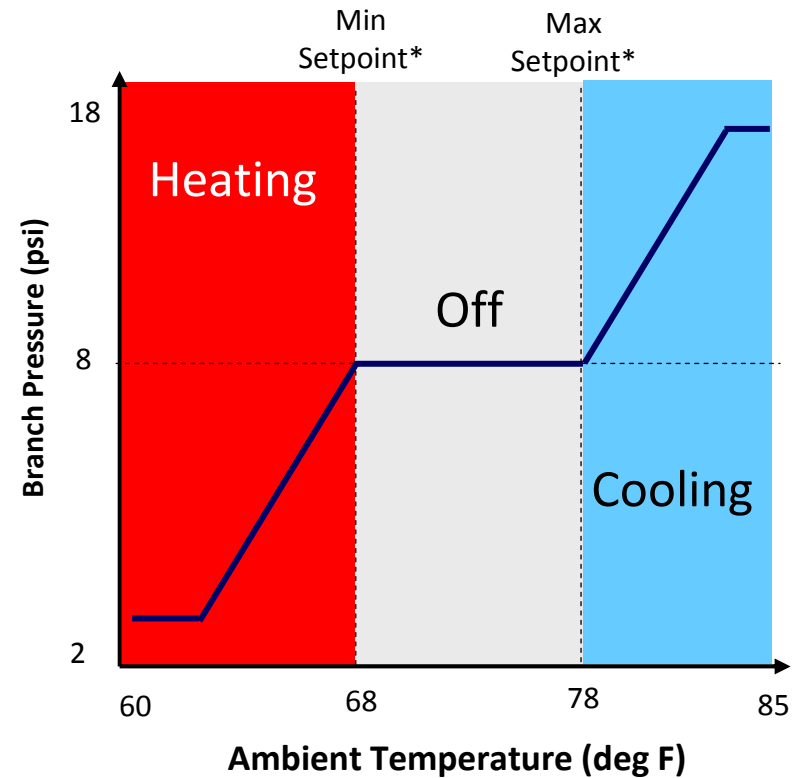

\*Minimum and Maximum Setpoints are selectable by user or building manager

# Energy Savings Enabled by Deadband

**Significant Savings!**

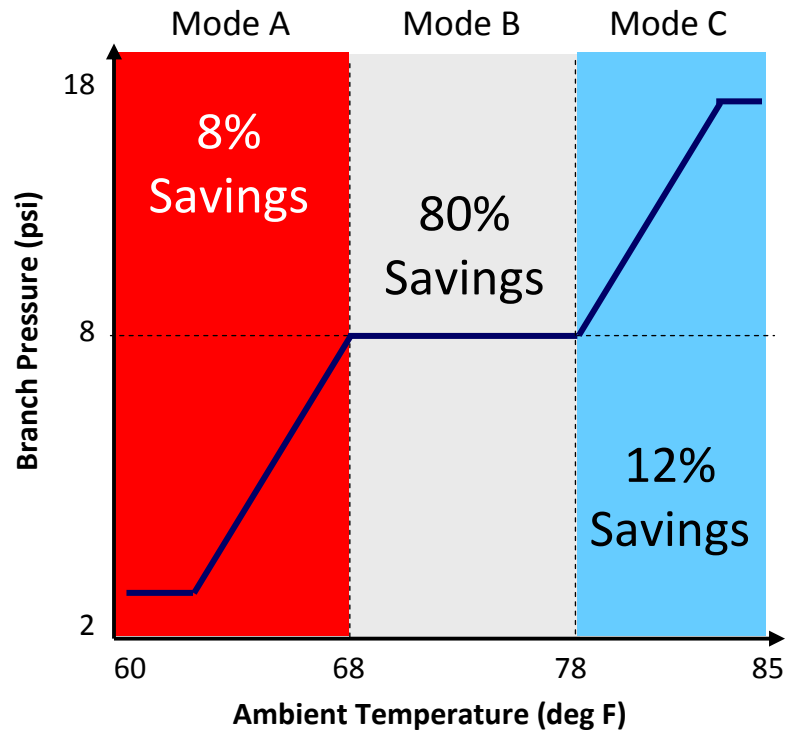

	% of time operating in:			Est. Energy Savings
	Mode A	Mode B	Mode C	
Location 1 (e.g. San Diego, CA)	20%	70%	10%	59%
Location 2 (e.g. Fargo, ND)	75%	20%	5%	23%
Location 3 (e.g. Miami, FL)	20%	50%	30%	45%

## Deadband Savings By Mode vs. Standard Stat

- Mode A – Min Setpoint 4F below conventional Setpoint => 8% energy savings.\*
- Mode B – Only ventilation fans running, no heat or cool => 80% energy savings.\*\*
- Mode C – Max Setpoint 6F above conventional Setpoint => 12% energy savings.\*

\* Every degree of setback equals 2% energy savings. Source: ACEEE.

\*\* Ventilation uses about 20% of the energy in HVAC even when cooling or heating is not active.

Source: US Energy Information Administration.

# Wireless Pneumatic Thermostat Savings

**Estimated Savings Potential**  
 \$635/year (per 1000 sq-ft)  
 Upfront Retrofit Cost: \$600 (per 1000 sq-ft)  
 Payback Period: 11 months

*Note: All calculations based on 300,000 sq-ft retrofit project, \$0.10 per kWh electricity rate, and \$80 per hour maintenance labor rate.*

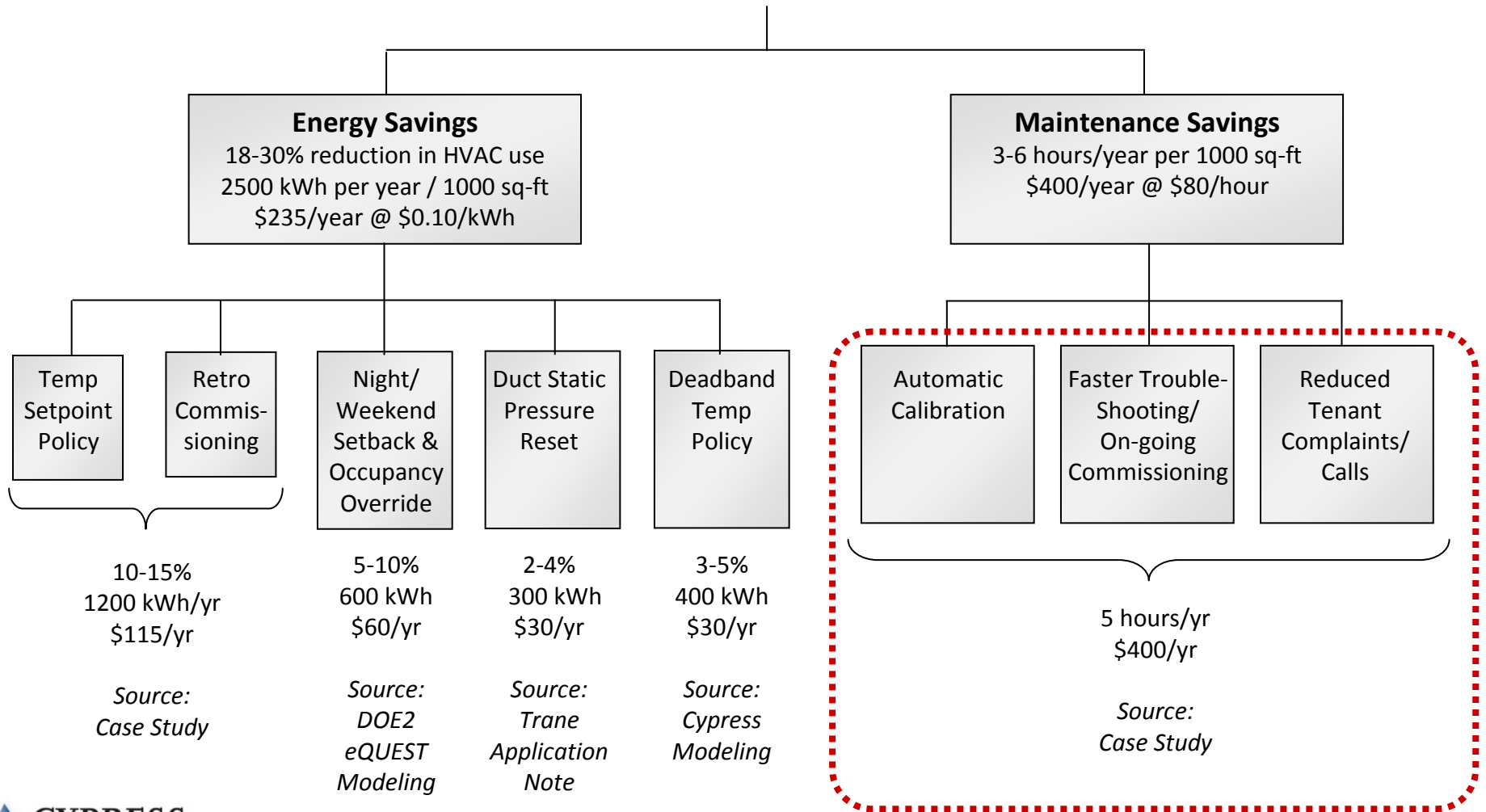

# Savings from Reduced Maintenance

- **Auto-Calibration**
- **Reduced Tenant Hot/Cold Calls:**  
Built-in BACnet and email alarm notification - before tenants complain.
- **Faster Troubleshooting/On-going Commissioning:**  
Built-in branch pressure, zone temperature, and setpoint temperature sensors with trending, history, and alarming. Service strategy converted from Scheduled Maintenance to Condition Based Maintenance, and enable Ongoing Commissioning.
- **Actual Case Study Results, Santa Clara County Government– 300,000 sq-ft retrofit**
  - 60% reduction in maintenance service – from \$25k/month to \$10k/month
  - Key learnings: predictively detect faults, dispatch service personnel only to zones with identified faults, and monitor to confirm fault is fixed post service call.

Full case study available at: [http://www.cypressenvirosystems.com/files/pdf/CountyofSantaClara\\_EnergySavings\\_Final.pdf](http://www.cypressenvirosystems.com/files/pdf/CountyofSantaClara_EnergySavings_Final.pdf)

**60% Reduction in Maintenance Service Hours by Dispatching Service Work Only to Detected Problem Areas, and Faster Troubleshooting**

# LEED Credits









## LEED for Existing Buildings: Operations & Maintenance Registered Project Checklist

			Energy & Atmosphere, continued			
			<b>Existing Building Commissioning</b>			
<input type="checkbox"/>	<input type="checkbox"/>	<input type="checkbox"/>	Credit 2.1	<b>Investigation and Analysis</b>	✓	2
<input type="checkbox"/>	<input type="checkbox"/>	<input type="checkbox"/>	Credit 2.2	<b>Implementation</b>	✓	2
<input type="checkbox"/>	<input type="checkbox"/>	<input type="checkbox"/>	Credit 2.3	<b>Ongoing Commissioning</b>	✓	2
			<b>Performance Measurement</b>			
<input type="checkbox"/>	<input type="checkbox"/>	<input type="checkbox"/>	Credit 3.1	<b>Building Automation System</b>	✓	1
<input type="checkbox"/>	<input type="checkbox"/>	<input type="checkbox"/>	Credit 3.2-3.3	<b>System Level Metering</b>		1 to 2
			Credit 3.2	40% Metered		1
			Credit 3.3	80% Metered		2

***Tenant Comfort and Satisfaction, Ability to Attract Top Tier Tenants, and Lower Lease Churn Rates Are Incremental to Energy Savings Benefits***

# Compatible with Existing Systems

VENDOR	BAS	TEST PARTNER	LOCATION
	BACtalk	Syserco	Fremont, CA
	ALC	ACCO Engineered Systems	San Leandro, CA
	Excel, Tridium	Honeywell Corp.	Golden Valley, MN Wixom, MI
	Metasys	RSD-Total Control JCI Sensor Products	San Jose, CA Milwaukee, WI
	Apogee	Siemens Building Technologies	Hayward, CA
	Andover Continuum	EMCOR Integrated Solutions	Pleasanton, CA
	Trane Tracer Summit BCU	Trane	Calgary, Alberta - Canada
	ORCA	Cypress Semiconductor	San Jose, CA

Cypress Envirosystems™ and its logo are trademarks of Cypress Envirosystems, Inc. The name of any other company, products, or services mentioned herein are for identification purposes only and may be trademarks, registered trademarks, or service marks of or may be copyrighted by their respective holders. © Copyright 2008 Cypress Envirosystems, Inc. All rights reserved.



# Current Wireless Pneumatic Thermostat (WPT) Architecture

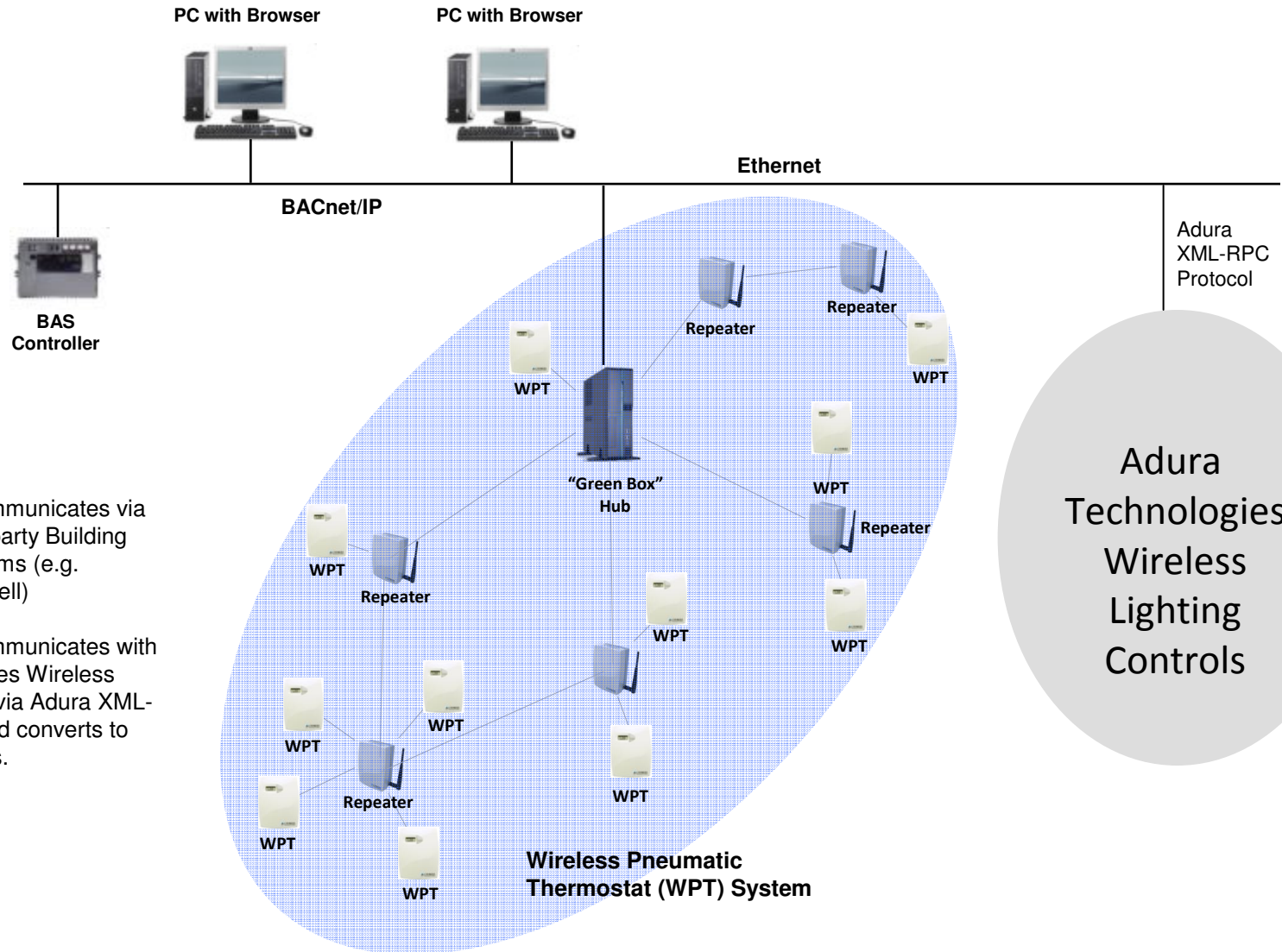

**Notes:**

WPT System Communicates via BACnet/IP to 3<sup>rd</sup> party Building Automation Systems (e.g. Johnson, Honeywell)

WPT System Communicates with Acura Technologies Wireless Lighting Controls via Acura XML-RPC interface, and converts to BACnet/IP objects.

# Authorized Channel Partners

## GOLD CHANNEL PARTNERS



## SILVER CHANNEL PARTNERS



# Selected Cypress EnviroSystems Customers

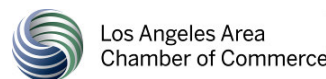

# Selected WPT Customer Feedback

First and foremost, the work performed by the professional team at Cypress Envirosystems was seamless. The installation was very precise and strategic, the training both clear and complete, the knowledge and understanding of customer needs concise and competent. As a business partner Cypress Envirosystems is top notch and I will refer and recommend to all my company peers the same. Thanks again for a job well done and the support and training that was second to none. Thanks again for a great job.

Lawrence Riviera  
**Honeywell Building Solutions**

It was an outstanding and record setting installation of the wireless pneumatic thermostats and they are all working great. Everyone in the Dean's Office is very happy and impressed. So far everything is great. Thanks for your efforts and please send my best regards to your colleagues.

Emir José Macari, Ph.D.  
Dean of Engineering and Computer Science  
**California State University, Sacramento**

In just five days, we went from zero control of our heating and air conditioning, to total control. It was amazing how easy it was to calibrate each WPT after installation. Now we control set points for all thermostats remotely and have programs in place to control them according to all sorts of variables. We now have a true wireless EMS system. We can go online and see every zone and control each one remotely. The WPT system also gives us very powerful diagnostic tools and troubleshooting tools.

Paul Becker, Facilities Manager  
**Kaiser Permanente**

The whole project, including installation, cost about \$175,000 for retrofitting 350 thermostats," says Ortega. "We made the deadline and received the PG&E incentive of \$200,000. Talk about instant ROI. Plus, we figure that we are saving \$42,000 per year on electric cost for just those two buildings. And then there's maintenance. We used to be out there all the time tinkering with the system. Now we monitor it online. We figure our maintenance expense has been cut in half from \$25,000 annually to \$12,500.

Lin Ortega, Utilities Engineering Program Manager  
**Santa Clara County, California**

We are excited about our new level of control on the 2 floors that were retrofitted!

**Timothy D. Danz**  
Chief Engineer, The California Center  
Cushman & Wakefield  
San Francisco CA 94104

The new WPTs are working great. We now remotely control setpoints, set alarms, run diagnostics, perform zone control, and occupancy override. Of course, some of the tenants complain that they have lost control of their thermostats, but I point out that the university has a setpoint policy of 70 degrees for heating and 74 degrees for cooling. At night we go to 60 and 85 degrees. Thanks to the new WPTs, this is the first time we've been able to implement the policy in that building."

Kirk Dillery, Energy Systems Specialist  
**Western Michigan University**



# ***Lighting Controls Retrofit***

# Easy Retrofit of Existing Fixtures

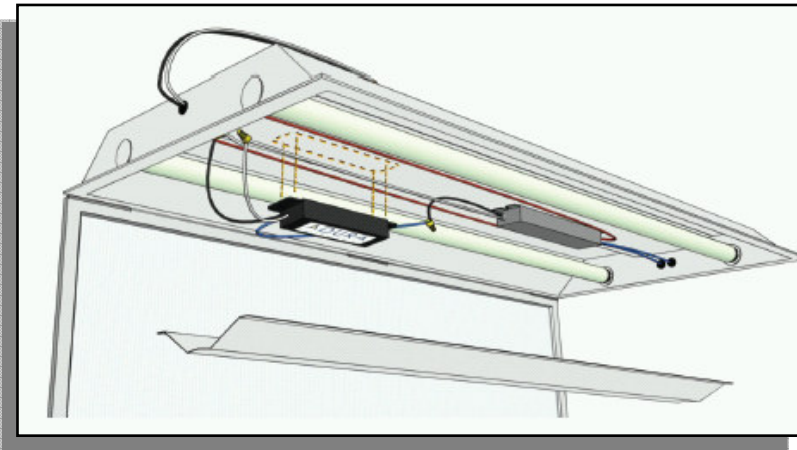





Lighting Controller



Occupancy or Light  
Sensor Interface

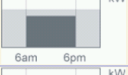

Wall Control  
Interface

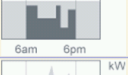
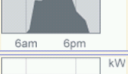
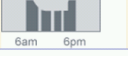
Strategy Employed	Savings Expected	
Smart Scheduling	10-40%	
Daylight Harvesting	5-15%	
Task Tuning	5-20%	
Presence Detection	25-50%	
Personal Control	5-15%	
Demand Management	5%	
<b>Total</b>	<b>50-75% (Blended)</b>	

*“Plus....sophisticated Enterprise Energy Management software designed to work with your lighting system to save energy”*



# ***Energy Auditing & Continuous Commissioning***

# Cypress Envirosystems: Problems We Solve...



*Pneumatic  
Thermostats*



*Dial Gauges*



*Steam Traps*

Need to save energy & improve uptime, but hindered by outdated facility?



*Standalone Transducers,  
LED/LCD Displays*



*-80C Freezers*



*Legacy Fluorescent  
Lighting*



*Uninterruptible  
Power Supplies*

**Manual Instrumentation, Not Programmable, No Diagnostics...  
Equals: Wasted Energy, Higher Downtime, More Labor Required**



# What is our Solution?



**WIRELESS PNEUMATIC THERMOSTAT**  
*"Go from Pneumatic to DDC in minutes"*



**WIRELESS GAUGE READER**  
*"Remotely Read Gauges in minutes"*

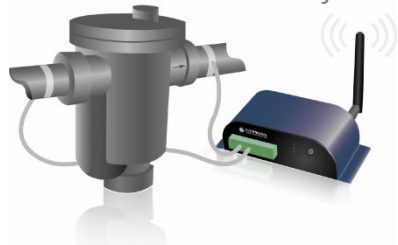

**WIRELESS STEAM TRAP MONITOR**  
*"Avoid Expensive Steam Leaks"*



**BLUE BOX HUB/RECEIVER**



**WIRELESS TRANSDUCER READER**  
*"Remotely Read Transducers – No Wires"*

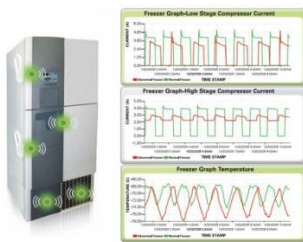

**WIRELESS FREEZER MONITOR**  
*"Predicts and Avoids Costly Freezer Failure"*



**WIRELESS LIGHT CONTROLLER**  
*"Reduce Electricity Use"*



**WIRELESS BATTERY MONITOR**  
*"Automates UPS Health Check"*

**Non-invasive, easy retrofit, energy and labor savings, payback under one year**

# Energy Audits, Continuous Commissioning



Typical Air Handler Units



Wireless Magnetic Reader  
Monitors Filters and Airflow

- Chilled Water, Steam, Airflow are tough to measure in legacy buildings
- Most older Air Handler Units, Chillers, Boilers etc. are not monitored/automated
- Labor intensive to detect problems, check filters
- Manual gauges often the main means to check pressure, temperature, flow
- Solution: Wireless Gauge Reader clamps on in minutes and transmits reading wirelessly to BMS/BAS
- No downtime, no wiring, no leak checks
- Alarm notification and condition-based maintenance



Wireless Readers  
Mounts Over Existing Gauges

***Enables Monitoring of Legacy Air Handlers for 70% Less Than Traditional Transducers***

# Wireless Steam Trap Monitor (WSTM)

## CYPRESS ENVIROSYSTEMS WIRELESS STEAM TRAP MONITOR

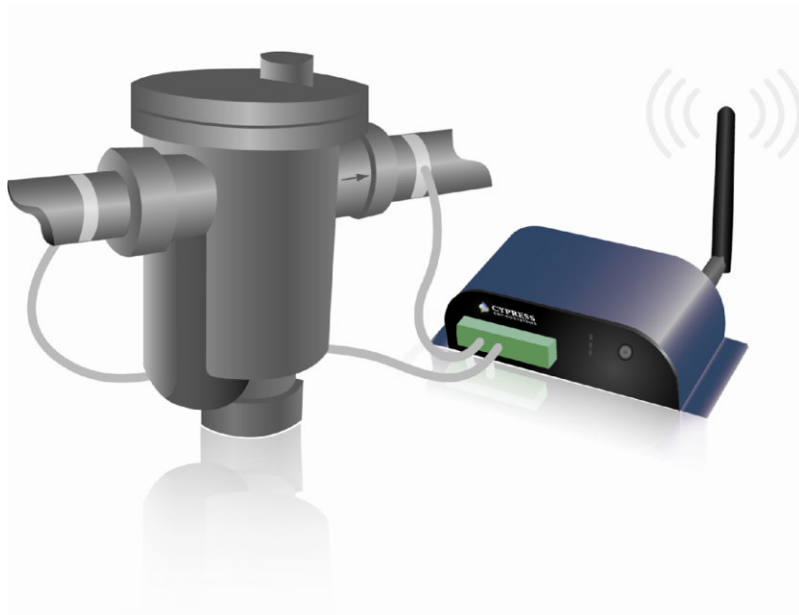

- Necessary part of the steam distribution system, usually hundreds of units per site
- 15-20% average failure rate; leaks steam
- Failed traps lose \$5,000 per year (1/8" orifice)
- Manual inspection typically done annually – labor intensive, do not catch problems in timely manner
- Solution: Wireless steam trap monitor detects faults and alarms on error, avoiding expensive leak loss
- Non-invasive installation: no breaking seals, wireless, integrates with BMS
- Battery life of 3+ years at typical sample rates
- IP65/NEMA 4 rated for outdoor use
- One year payback on investment



Leaking Traps Waste Energy



Typical Steam Trap

**Save Energy and Time Locating Faulty Steam Traps**

# How Steam Trap Monitoring Saves Energy

Without Steam Trap Monitoring

With Steam Trap Monitoring

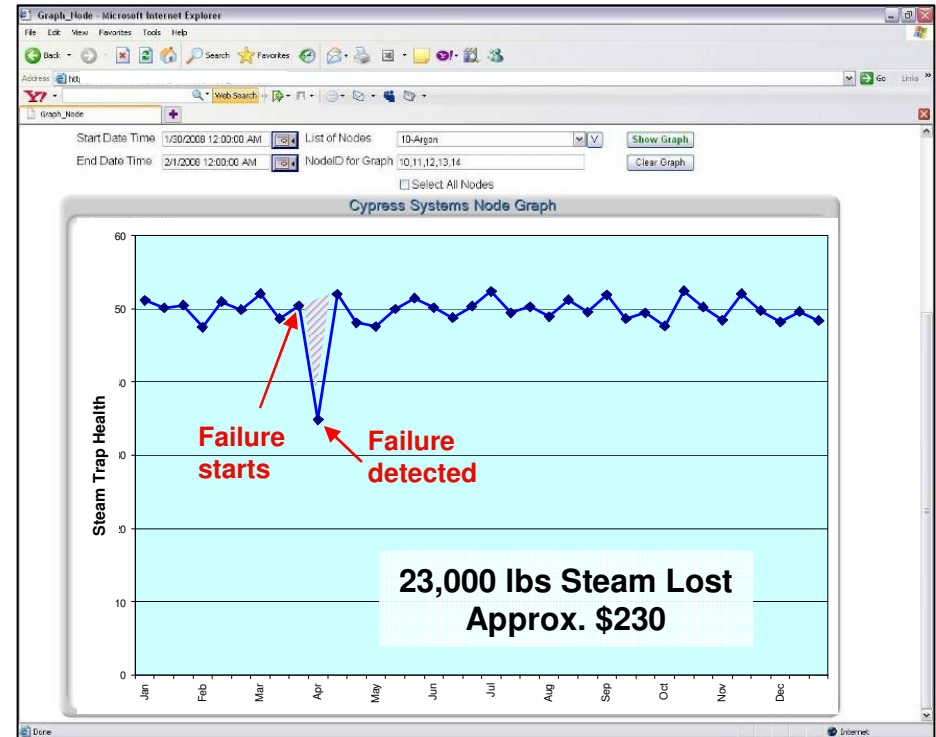
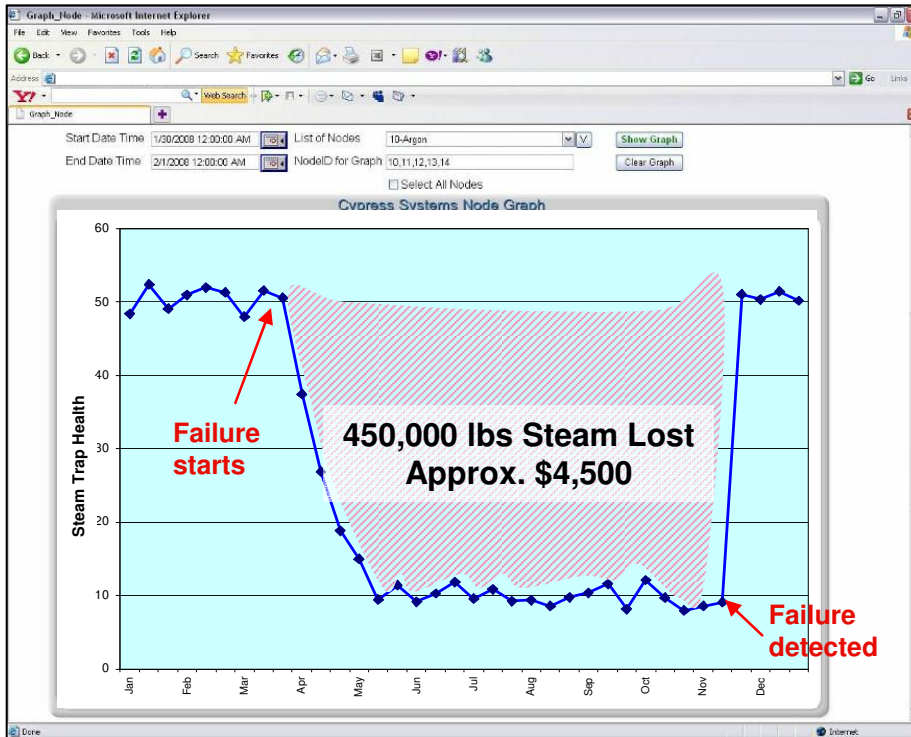

Typical savings for 1/8" orifice steam trap

**Timely Detection and Correction of Trap Failures Avoids Prolonged Costly Steam Leaks**

# Summary

- Retrofit for Commercial and Industrial Plants for Energy Efficiency and Auto-Demand Response
- Key Principles:
  - Non-Invasive, Clamp-on Devices Which Install in Minutes
  - Compatible with Existing Infrastructure
    - DDC Integration
    - No new training of staff
    - No new systems software
- Typical Payback of 18 Months or Less



# ***Additional Backup Examples***

# Reduce Energy Consumption: Compressed Air

## Customer Challenge:

Compressors, pumps and fans often run at settings beyond what is needed e.g. 125psi for Compressed Dry Air instead of 85psi, wasting >20% energy.

Operators lack monitoring so they don't reduce pressure – avoid risk of process upset.

Installing transducers is very time-consuming & disruptive for multiple air branches and can introduce leaks.

## WGR Solution:

Typically manual gauges are already installed throughout CDA systems or coolant loop systems.

WGR's can monitor and alarm pressure/flow to ensure process integrity and reduce energy use.

App note available:  
*"Compressed Dry Air System Energy Savings"*



**Savings on 500hp Compressed Air System can be up to \$100K per year, with a 8 month payback.**

# Improve Asset Health and Uptime

## Customer Challenge:

Older equipment such as packaged heat exchangers, boilers, chillers, air dryers, hydraulic conveyors, water filters, HEPA filters, etc. often have little or no electronic monitoring outputs.

Adding new transducers require modifying the equipment package and may impact existing service/warranty agreements.

## WGR Solution:

Typically manual gauges are already installed on older packaged equipment.

The WGR can monitor, trend and alarm parameters for early fault detection and corrective action.

Case Studies Available:  
*“Facilities Monitoring”*

*“Tri-State Power Asset Health Monitoring”*



**“In the first two weeks of using the WGR, we were able to detect and develop corrective measures for a potentially costly issue that we never suspected” – Mike Long, Control System Supervisor, Tri-State Generation and Transmission**



# Reduce Consumables Usage

## Customer Challenge:

Gas cylinders (e.g. cal gases), water filters, HEPA filters are often replaced at scheduled intervals rather than actual usage.

This results in more frequent changes than required, or results in downtime when not replaced in a timely manner.

Installing transducers may introduce leaks and require safety inspection.

## WGR Solution:

Gas Cylinder regulators gauges, Magnehelic air flow gauges (for HEPA filters) are great examples of data which can be read and trended to optimize consumables use.

Reduces consumables cost, avoids downtime, and optimizes skilled labor.

Case Studies Available:  
*"Micrel Gas Management Savings"*



**We saved \$215K per year on our 280 Gas Cylinders, a seven month payback.  
– Ron Farry, Operations Manager, Micrel Inc.**

# Perform Faster Troubleshooting

## Customer Challenge:

When excursions occur, technicians inspect many gauges and equipment in the hope of finding the source of the problem...but the relevant data was often not captured and is not available.

Often, data from different subsystems or equipment needs to be compared and time-indexed to identify the root cause.

## WGR Solution:

The WGR may be permanently or temporarily installed to log data, and notify on excursions.

The time-indexed historical record helps reduce troubleshooting time and confidence.



**Minimize Troubleshooting Labor and Downtime with  
Non-Invasive Data Logging of Historical Data**

# Enhance Safety, Reduce Incidents

## Customer Challenge:

Many facilities perform manual rounds to inspect equipment and log gauge readings.

Some gauges are in awkward locations or may pose safety risks - high up on column, near heat sources, under floor etc.

Accurately reading gauges “face-on” (without parallax) are sometimes difficult or impossible.

## WGR Solution:

Wherever there is a gauge in a hard-to-access location that needs to be read, the WGR is a fast and low cost candidate to do the job.

Reduce likelihood of safety incidents due to reading gauges in hard-to-access locations.



**“I’m not getting more engineers, so I need to have them working smarter...using the WGR”  
- Pat Ireland, Operations Manager, Novellus Inc.**